

## **SMALL VOLUME (53ML) EIC WITH ON/OFF MECHANISM**

Frederick Stieff and Paul Kotrappa

Rad Elec Inc.  
Frederick, MD 21704  
PKotrappa@aol.com

### **Abstract**

The small volume “L” Chamber (58 ml) Electret Ion Chamber (EIC) that was previously manufactured by Rad Elec Inc. did not incorporate a mechanism that allowed the chamber to be turned on and off. To rectify this problem, a re-designed small volume chamber, designated an “L-OO” Chamber, is currently being produced by Rad Elec. This newly designed L-OO Chamber (53 ml) incorporates a slide mechanism with an aperture that can be positioned over the electret in the “open” position while a solid section of the slide mechanism covers the electret in the “closed” position. The new L-OO Chamber does not respond to ionizing radiation that may occur during transit or storage. These new devices, designated as a LST-OO when loaded with a ST Electret or a LLT-OO when loaded with a LT Electret, have been approved by the NEHA-NRPP and have been assigned the following device codes: LST-OO is 8230-25 and LLT-OO is 8234-25. The L-OO Chambers, which are significantly less expensive than “S” Chambers, have been designed for radon measurements lasting from approximately 30 days to 365 days, depending upon the type of electret being used.

### **Introduction**

The existing 58 ml “L” Chamber did not have an “on-off” mechanism. This resulted in an additional background radiation contribution due to radon and gamma during transit or storage. Previously, to minimize this “background” contribution, a user was instructed to keep the transit/storage time to an absolute minimum, or to store the electret being used in its “keeper cap” during transit/storage. The user was instructed to load the electret into the “L” Chamber just before the start of the exposure, and then unload the electret from the “L” Chamber and return it to its keeper cap while being transported or stored prior to analysis. These methods produced acceptable results, but introduced uncertainties due to handling of the electrets and background radiation. To rectify this problem, a re-designed small volume chamber, designated as an “L-OO” Chamber, is currently being produced by Rad Elec. This newly designed L-OO Chamber incorporates a slide mechanism with an aperture that can be

*Required Notice: The authors have a substantial financial interest in the product being featured in this paper.*

positioned over the electret in the “on or open” position while a solid section of the slide mechanism covers the electret in the “off or closed” position. The new L-OO Chamber does not respond to ionizing radiation that may occur during transit or storage. These new devices, designated as an LST-OO when loaded with an ST Electret or an LLT-OO when loaded with an LT Electret, were evaluated by the USEPA and approved by the certifying agency, NEHA-NRPP. They have been assigned the following device codes: LST-OO is 8230-25 and LLT-OO is 8234-25. The L-OO Chambers, which are significantly less expensive than “S” Chambers, have been designed for radon measurements lasting from approximately 30 days to 365 days, depending upon the type of electret being used.

### Schematics of the L-OO Chambers

**Figure 1** is a schematic of the L-OO Chamber in the “On” position. **Figure 2** is a schematic of the L-OO Chamber in the “Off” position. **Figure 3** is an actual photograph of the device that illustrates the L-OO Chamber in both the “On” and “Off” positions.

Figure 1 shows the L-OO Chamber in the “On” position. The slide or shutter is pulled until small detents or “stops” restrict the slide, which causes the “aperture” to be centered over an electret that has been loaded into the bottom of the chamber. There are also small holes in the slide mechanism where a “clip” or wire tie can be inserted which will prevent movement or manipulation of the slide during the testing period.

Figure 2 shows the L-OO Chamber in the “Off” position. In this case, the slide has been pulled in the opposite direction until the detents or “stops” are engaged, which causes the solid part of the slide to be positioned over the electret. There are small holes which allow a “clip” to be inserted to restrict movement of the slide during transit.

Figure 3 is an actual photograph of the device that illustrates the L-OO Chamber in both the “On” and “Off” positions.

### General Description of Electret Ion Chambers

An Electret Ion Chamber (EIC) consists of a stable electret mounted inside a chamber made of electrically conducting plastic. The electret, a charged Teflon<sup>®</sup> disk, serves as both the voltage source for ion collection and as the integrating ion sensor. Radon gas passively diffuses into the chamber through filtered inlets, and the alpha particles emitted during the decay process ionize air molecules. Negative ions produced inside the chamber are collected on the positively charged electret causing a reduction of its surface charge. The reduction in charge is a function of the radon concentration, duration of the testing period, and the chamber volume. The change in the surface charge (voltage) on the electret is measured with a specially designed electret voltage reader. Using the known or measured parameters, the radon concentration is calculated using provided algorithms. The basic components of the E-PERM<sup>®</sup> System consists of the SPER-1 Electret Voltage Reader, chambers and electrets manufactured by Rad Elec Inc., and software provided by the manufacturer. There are chambers of different sizes and electrets of different sensitivities to meet a wide range of monitoring situations (*References 1 and 2*).

There have been numerous publications and inter-comparisons (*Reference 3, 4 and 5*) of the EIC technology, which has been commercialized under the brand name E-PERM<sup>®</sup>, with other methods of measuring radon. These publications can be obtained from our website: [www.radelec.com](http://www.radelec.com).

### Discussion and conclusion

The L-OO Chamber improves an existing technology that has been in use for nearly twenty years. The current development of a small volume chamber with an “On/Off” mechanism is intended to reduce the cost for making long-term measurements using EIC technology without compromising accuracy or performance. These devices should compete very favorably with any other method for long-term measurements of radon gas.

### Appendix 1

#### Technical Specifications for LST-OO E-PERM<sup>®</sup>

**Purpose:** To make long term radon measurements from 30 days to 4 months

**Expected error:** Less than 10 % for radon concentration of 4 pCi/L or higher

**Maximum range:** Approximately 1,830 pCi/L-days

**True Integrating Device:** Radon monitors can be used for shorter periods at higher radon concentrations or longer periods for lower radon concentrations

**On-Off Mechanism:** Allows the user to easily turn the device “Off” during shipping and storage or easily turn the device “On” for the measurement of radon gas

#### Technical Specifications for LLT-OO E-PERMs<sup>®</sup>

**Purpose:** To make long term radon measurements from 4 months – 1 year

**Expected error:** Less than 10 % for radon concentrations of 4 pCi/L or higher

**Maximum range:** Approximately 20,000 pCi/L-days

**On-Off Mechanism:** Allows the user to easily turn the device “Off” during shipping and storage or easily turn the device “On” for the measurement of radon gas

#### Technical Specifications applicable to all E-PERM<sup>®</sup> Electret Ion Chambers

**Not affected by:** (under normal conditions typically found in homes)

Relative Humidity

Temperature

Dust

Air flow

Sunlight

Environmental ions

Magnetic fields up to 10,000 Gauss

Electric voltages up to 5000 volts  
Normal shocks while handling and shipping

**Response to Thoron:** Less than 3%

**Response to gamma radiation:** 0.6 pCi/L for 5  $\mu$ R/h, (corrections are made in calculations)

**Errors:** Errors are estimated by using the published algorithms used in calculations, taking into account all possible errors

**Calculations:** Device specific templates are provided for the respective devices to help performing the calculations

**Electret Voltage Reader:** CE certified – recommended to be used in air conditioned rooms with RH of less than 80%.

**E-PERM® Users Manual and Technical Publications:** Available on the web site at [www.radelec.com](http://www.radelec.com) or by special request

## Appendix 2

### Procedure for Making a Radon Measurement Using either an LST-OO or LLT-OO E-PERM®

LST-OO E-PERMs® are designed for radon measurements typically from 30 days to 4 months and LLT-OO E-PERMs® are designed for radon measurements for 4 months to one year.

A simple “clip” or wire tie is used to prevent accidental movement of the shutter during shipping and/or during the actual radon measurement. The shutter is used for turning the unit on and off. To turn the device “on”, the shutter is pulled until small detents or “stops” restrict the slide, which causes the “aperture” to be centered over an electret that has been loaded into the bottom of the chamber. There are also small holes in the slide mechanism where a “clip” or wire tie can be inserted which will prevent movement or manipulation of the slide during the testing period. To turn the device “off”, the shutter is pulled in the opposite direction until the detents or “stops” are engaged, which causes the solid part of the slide to be positioned over the electret. There are small holes which allow a “clip” to be inserted to restrict movement of the slide during transit.

The following steps are used when making a measurement with the LST-OO or the LLT-OO E-PERM®:

1. Take an Initial Voltage reading of the electret that is going to be used and “load” the electret (either ST or LT) into the bottom of the chamber. Turn the chamber to the “Off” position by pulling the shutter until the “stops” engage (the “aperture should be visible) and insert the “clip”. The device can now be transported or shipped.

2. At the test location remove the “clip” from the chamber, and turn the unit “On” by sliding the shutter until the “stops” are engaged. The “aperture” will now be centered over the electret (“aperture” will not be visible). Insert the “clip” to lock the shutter in position. Deploy the unit according to recommended protocols.
3. At the conclusion of the testing period remove the “clip” from the chamber, and turn the unit “Off” by sliding the shutter in the opposite direction until the “stops” are engaged (“aperture” should be clearly visible). Insert the lock “clip”. The device is now ready for transport or shipment.
4. At the place of analysis, unscrew the electret and measure the Final Voltage. The electret can be stored in the L-OO chamber or in the electret “keeper cap” until the next use.
5. The following information is required:
  - a. The test site address
  - b. The location of the device in the room
  - c. The Initial Volts (IV) and Final Volts (FV) of the electrets
  - d. The Start-Stop dates and times
  - e. The gamma radiation level at the test site
  - f. The elevation at the test site
6. Use the appropriate Software or Template for calculations.

## **References**

1. P. Kotrappa, J.C. Dempsey, R.W. Ramsey, and L.R. Stieff “A Practical E-PERM™ (Electret passive environmental radon monitor) System for Indoor 222Rn Measurement” Health Physics 58:461-467 (1990)
2. P. Kotrappa and L.R. Stieff “Elevation correction factors for E-PERM® Radon Monitors” Health Physics 62:82-86 (1992)
3. S. Kainan, M. Majdan, D.W. Field, and R.W. Field “Field Comparison of Commercially Available Short-term Radon Monitors” Health Physics:91:221-226 (2006)
4. A.Vargas and X.Ortaga “Influence of Environmental Changes on Integrating Radon Detectors: Results of an International Exercise” Radiation Protection Dosimetry 123:529-536 (2007)
5. S. Kainan, G. Budd, S. McLemore and R.W. Field “Blind Testing of Commercially Available Short-term Radon Detectors” Health Physics:94:548-557 (2008)

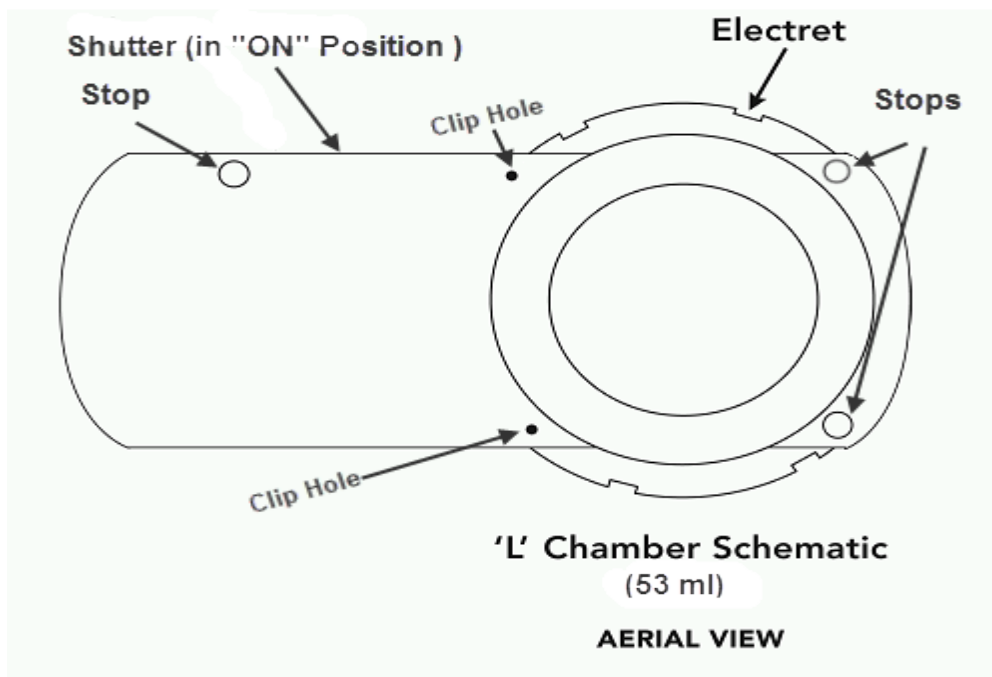
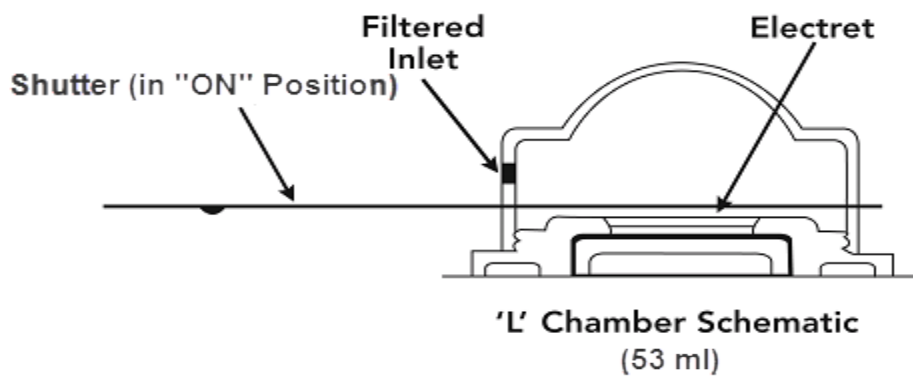

**Figure 1**

Device is in the "ON" position. A lock clip is inserted through the opening (black dot) to lock the device to prevent accidental movement of the shutter. The round circles indicate the bumps serving as stops.

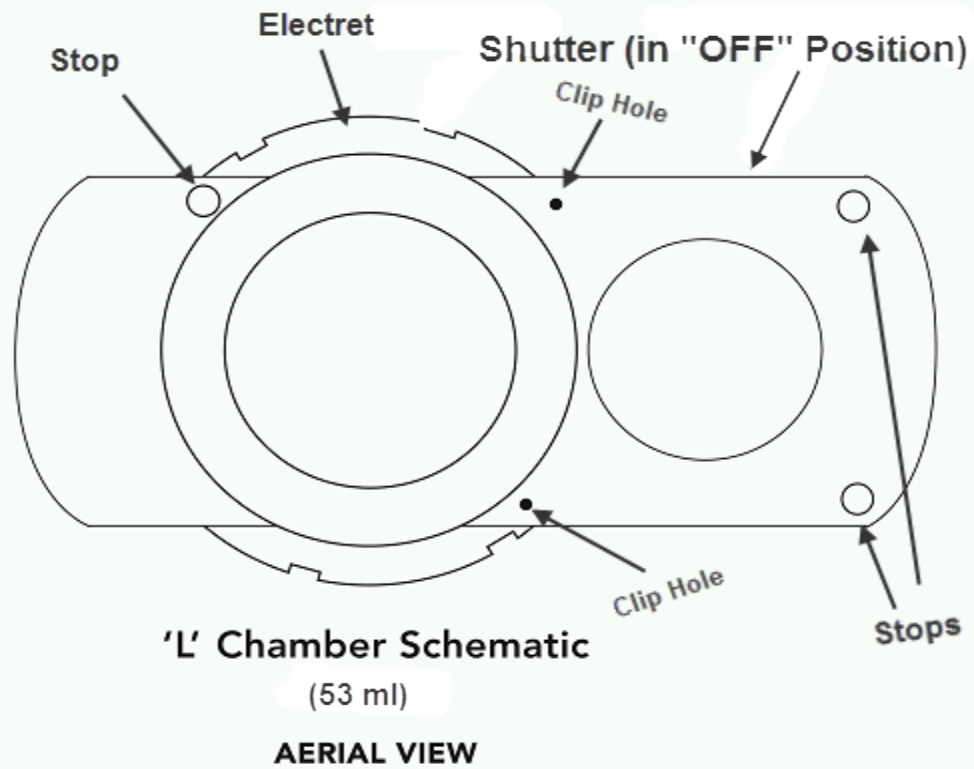
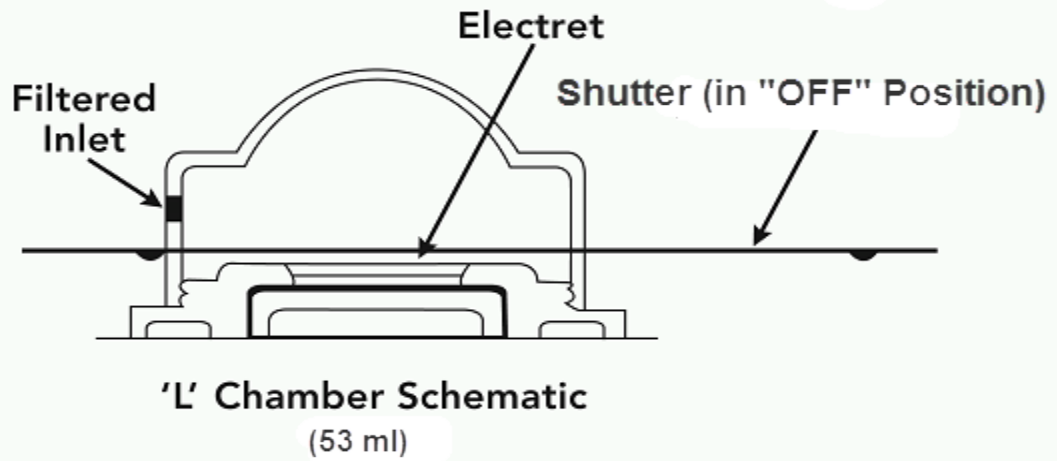

**Figure 2**

Device is in the “OFF” position. A lock clip is inserted through the opening (black dot) to prevent accidental movement of shutter. Circles indicate physical bumps to serve as stops at appropriate positions.

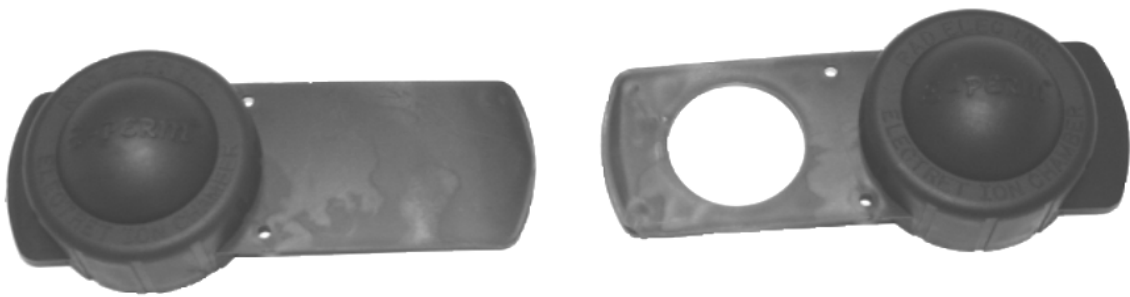

**Figure 3**

Photograph of an L-OO Chamber

Picture on the left is in the “ON” position. Picture on the right is in the “OFF” position.



