

ELECTRET ION CHAMBER RADON MONITORS MEASURE DISSOLVED ^{222}Rn IN WATER

P. Kotrappa* and W. A. Jester†

Abstract—This paper describes a simple and relatively inexpensive method of determining the concentration of dissolved ^{222}Rn in water. The method involves a recently developed electret-passive environmental radon monitor, which uses an electret ion chamber. The procedure consists of sealing a known volume of a carefully collected water sample with one of these monitors in an exposure container and determining the average equilibrium ^{222}Rn gas concentration in the air phase during the exposure time period. This average concentration can then be used to calculate the ^{222}Rn concentration in the original water sample. Identical samples were analyzed both by this new method and by a standard liquid scintillation method, and the results were compared over a wide range of ^{222}Rn concentrations. There was good agreement except that the electret ion chamber method gave results that were consistently lower by about 15%. This bias in the results was attributed to both ^{222}Rn losses during sample handling and possibly to some errors in the assumptions made in the theoretical model. A correction factor is recommended to bring the results of this technique into agreement with the standard method. The procedures are simple and economical and can be easily employed by many primary ^{222}Rn -measuring laboratories currently using these monitors for measuring indoor ^{222}Rn .

Health Phys. 64(4):397–405; 1993

Key words: ^{222}Rn ; water; ionization chamber; electrets

INTRODUCTION

THERE IS NOW growing concern over the health hazard associated with dissolved ^{222}Rn in public and private water supplies. The U.S. Environmental Protection Agency (EPA) has proposed a new regulation restricting the amount of dissolved ^{222}Rn in water to 11 Bq L^{-1} (300 pCi L^{-1}) in public drinking water supplies (U.S. Federal Register 1991).

The potential health hazards from the dissolved ^{222}Rn in private well water can be considerably higher than found in most public water supplies. In such wells, there is little or no opportunity for ^{222}Rn to escape or decay significantly before reaching the consumer (Dixon and Lee 1988).

Previous methods for measuring ^{222}Rn

Several methods have been developed over the years for measuring dissolved ^{222}Rn in water. One method (Mathieu et al. 1988) involves extracting ^{222}Rn from a water sample using helium gas; the ^{222}Rn gas is then trapped on cold charcoal. Subsequently, the charcoal is heated to drive out the gas, which is then collected into an evacuated Lucas cell for radioactive counting. A direct small volume transfer to a Lucas cell without adsorption on charcoal is another variation (U.S. EPA 1987) of this method.

A second method involves collecting small-volume water samples in a syringe or other appropriate sampling device. The water sample is immediately injected into a liquid scintillation vial beneath a layer of mineral oil scintillation fluid. After about 2 h of equilibrium time, the sample is counted (using a liquid scintillation counter) for its alpha radioactivity.

A third method involves collecting water into a standard-size container, followed by gamma-ray spectroscopy (Countess 1978). A fourth method uses a solid-state nuclear track detector (SSNTD) that is placed in the air volume in a closed container holding a water sample. The SSNTD determines the average ^{222}Rn concentration in the air phase. The concentration of ^{222}Rn in air is then used to determine the initial ^{222}Rn concentration in the water sample.

The first procedure involves the use of delicate sample collection equipment. The second and third methods involve expensive radiation-counting equipment. The fourth method employs expensive alpha-track counting equipment and lacks the sensitivity needed at low ^{222}Rn concentrations. These methods are also described in other publications (Lowry 1991; Vitz 1991).

New method

The procedure presented and standardized in this work involves the recently developed inexpensive electret ion chambers manufactured under the brand name E-PERMs® (electret passive environmental ^{222}Rn

* Rad Elec Inc., 5714-C, Industry Lane, Frederick, MD 21701;
† The Pennsylvania State University, University Park, PA 16802.

(Manuscript received 31 December 1991; revised manuscript received 31 July 1992, accepted 27 October 1992)

0017-9078/93/\$3.00/0

Copyright © 1993 Health Physics Society

† E-PERM® is a registered trademark of a patented product (Patent Nos. 4,853,536 and 4,992,658) manufactured by Rad Elec Inc., 5714-C, Industry Lane, Frederick, MD 21701. The technique described in this work is partially covered in U.S. Patent No. 5,055,674 entitled "Electret ionization chamber for monitoring radium and dissolved radon in water" assigned to Rad Elec Inc.

monitors). These monitors are fully described elsewhere (Kotrappa et al. 1988, 1990). These monitors are not affected by high humidity which makes them useful for this application.

The procedure consists of placing a known volume of carefully collected water in a ^{222}Rn leak-tight container and determining the average equilibrium ^{222}Rn gas concentration in the air phase using an E-PERM monitor. This concentration can then be used to calculate the ^{222}Rn concentration in the original water sample. The method is somewhat analogous to the fourth method referred to previously.

A detailed theory is presented in this paper. The developed procedures permit the variation of several parameters to arrive at optimum parameters for a particular application.

MATERIALS AND METHODS

E-PERM ^{222}Rn gas monitors

The ^{222}Rn monitors employed in this work are electret ion chambers (EIC). An electret is a charged Teflon[®] disk. It is characterized by a measurable surface voltage. When an electret is installed into an electrically conducting chamber, the combination becomes an EIC. It is an integrating ionization chamber with the electret serving not only as a source of the electric field but also as the ^{222}Rn sensor. The drop in surface voltage of the electret over a period of time is a measure of time-integrated ionization occurring during that period. An EIC with a filtered hole becomes a ^{222}Rn gas monitor since ambient ^{222}Rn gas diffuses into the chamber. The EICs are provided with an arrangement to expose or isolate the electret from the ^{222}Rn gas in the chamber to precisely control the time of measurement.

Fig. 1 shows a schematic of one such E-PERM unit. The surface voltage of the electret can be measured by a noncontact electret voltage reader. The method of measuring airborne ^{222}Rn consists of the following steps: 1) measure the initial surface voltage of the electret; 2) place the E-PERM in the desired location; 3) turn on the E-PERM by lifting the electret cover; 4) expose the E-PERM for a known time period; 5) turn off the E-PERM by lowering the electret cover; and 6) calculate the average ^{222}Rn concentration in that interval using appropriate calibration factors.

These detectors are now widely used for indoor ^{222}Rn monitoring by more than one-third of all the EPA-listed ^{222}Rn measuring companies in the U.S. Please refer to the published papers (Kotrappa et al. 1988, 1990) for further details. For the rest of this discussion, it is assumed that E-PERMs measure ^{222}Rn gas concentrations as low as 0.37 Bq L^{-1} (10 pCi L^{-1}) in air with $<10\%$ error when measured over 1 d. (Electrets of different sensitivities and chambers of different volumes are used to measure different concentrations and measurement time periods.)

[®] Teflon[®] is the registered trademark of E.I. duPont de Nemours and Co., (Inc.), Wilmington, DE 19898

(Electret-Passive Environmental Radon Monitor) Schematic

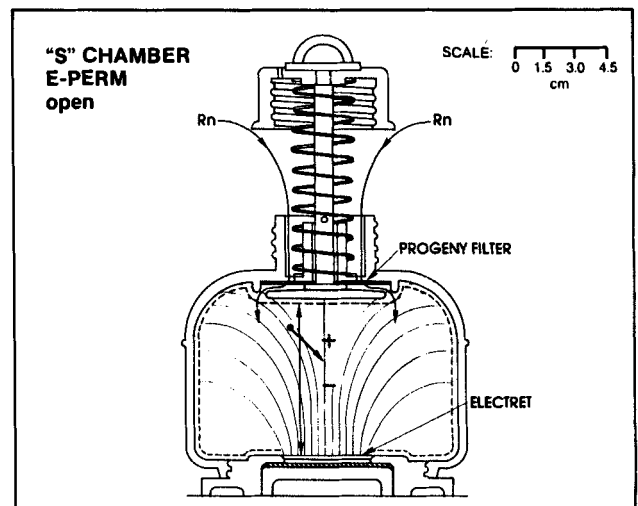
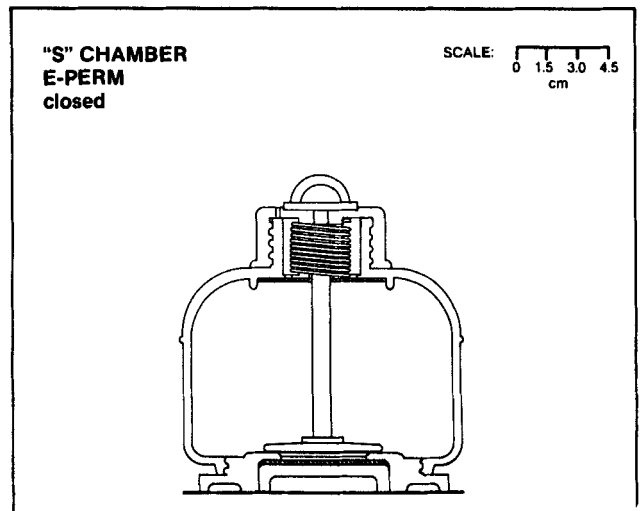

Fig. 1. Schematic of electret ion chamber-based E-PERM ^{222}Rn gas monitor. Upper window shows the E-PERM in its "off" position and the lower window shows the E-PERM in its "on" position.

Experimental Procedures

Water samples were carefully collected in small (67-mL) sample bottles with Teflon-lined screw caps using the protocol suggested by the U.S. EPA (1987). The procedures used in this method are illustrated in Fig. 2.

A glass analysis bottle of known volume was placed on its side (position 1 of Fig. 2). The lid of the sample bottle was removed and the bottle was quickly placed in an upright position in the clip inside the analysis bottle. A screw cap with an attached E-PERM (premeasured and in open position) was screwed onto the bottle. The analysis bottle was then placed upright, (position 2 of Fig. 2) spilling the water out of the sample bottle.

RADON-IN-WATER MEASUREMENT

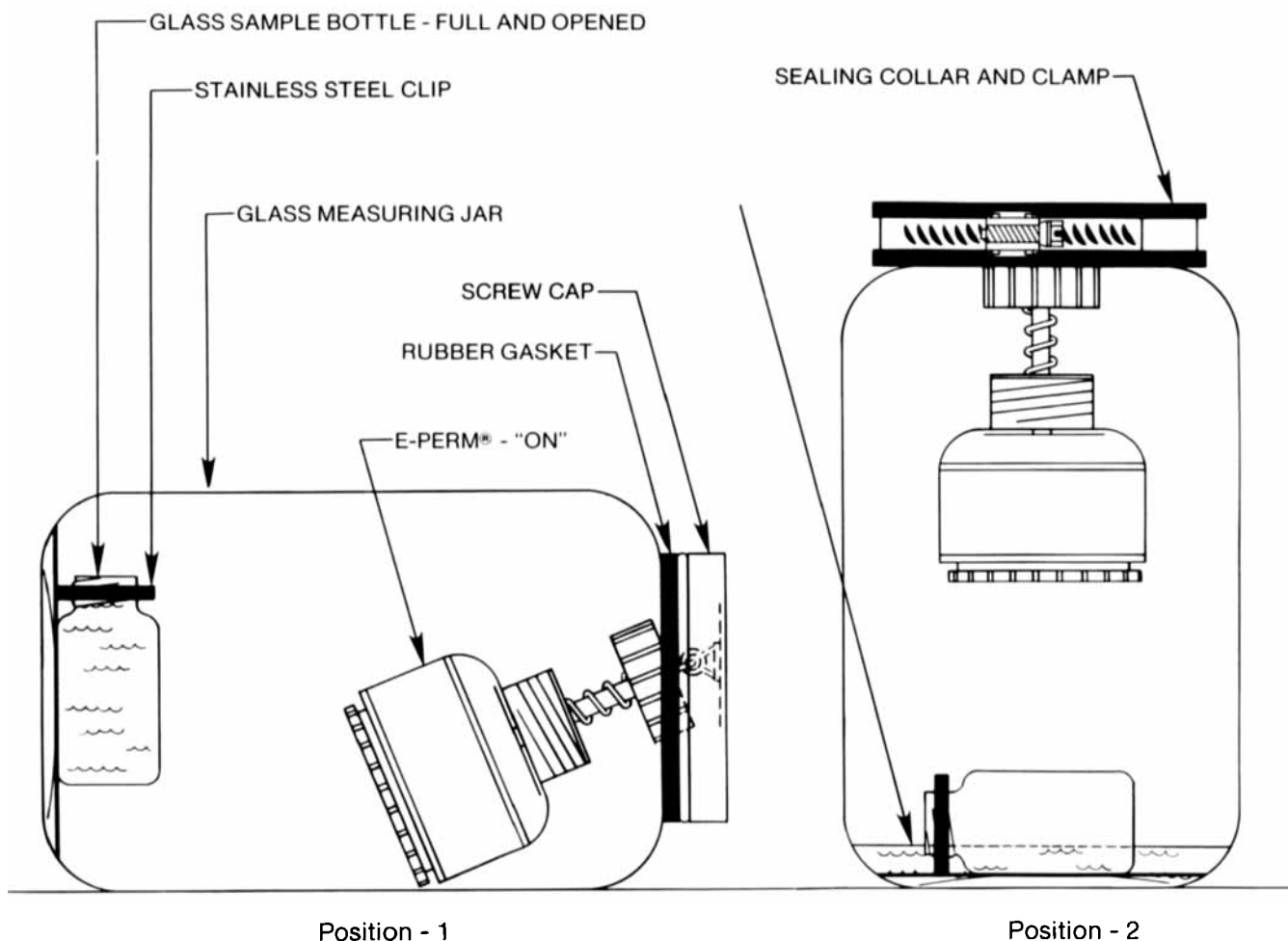

Fig. 2. Schematic of arrangements for measuring dissolved ^{222}Rn in water using electret ion chamber-based E-PERM ^{222}Rn gas monitor.

The analysis bottle was then sealed with a special rubber collar and shaken a few times to help release ^{222}Rn into the air phase. The steps taken from opening the sample bottle to closing the lid of the analysis bottle should be accomplished quickly to minimize ^{222}Rn loss from the sample.

After measuring for at least 1 d, the rubber collar and the screw cap were removed. The electret in the E-PERM was measured. The data on the initial electret voltage, final electret voltage, and the time period of exposure, were used to calculate average ^{222}Rn concentration in the air phase during the exposure period. This result was then used to compute the ^{222}Rn concentration in water using the theory developed in a later section entitled "Theoretical Considerations."

Sampling

Readily available water sample bottles, 67 mL in volume, were used, thus VW was 0.067 L. The bottles

were standard laboratory sample bottles with Teflon[®]-lined screw lids. A readily available ~4-L bottle was used as an analysis bottle. The analysis bottle was modified as shown in Fig. 2. The water sample bottle was fitted into the bottom clip. An E-PERM hung from a hook attached to the screw cap. The analysis bottle was fitted with gaskets, a screw cap, and appropriate rubber collars to avoid radon leaks. After deducting the volume of the water sample and bottle as well as the air volume occupied by the E-PERM, the air phase volume of the bottle measured 3.76 L. Thus, V_A was 3.76 L. The ^{222}Rn leak tightness was experimentally verified by leaving the sealed unit in a chamber that had high ^{222}Rn concentrations. No ^{222}Rn was detected leaking into the bottle, as measured by an enclosed E-PERM.

For these tests, samples were collected from a private well known to have high concentrations of dissolved ^{222}Rn in water. The water was allowed to run

for 15 min from a tap with a spout immersed in the flowing water in a 20-L bucket. This step was required to bring the well water to a constant ^{222}Rn concentration before collecting the samples. Water continued to flow during the sample collection. Samples were collected by opening the sample bottle inside and at the bottom of the bucket. After completely filling with water, the bottle was capped under the water and then removed from the bucket. Samples did not contain air bubbles. If an air bubble was found, the sampling was repeated. Nearly 150 such samples were collected over 20 min. Since all samples were collected in this short interval, they were expected to have the same dissolved ^{222}Rn concentrations. The bottles were properly labeled to identify their sequence of collection, then used for the experiments conducted in this study.

THEORETICAL CONSIDERATIONS

^{222}Rn gas has a relatively low solubility in water. Its partition under equilibrium conditions between the liquid and the gas phase is usually characterized by the Ostwald Coefficient (OC), which defines the ratio of the ^{222}Rn concentration in the liquid phase to the concentration of radon in the air phase (Clever 1979). Table 1 gives the values of this coefficient for a range of temperatures from 273 to 313°C. This coefficient decreases when minerals, such as sodium chloride, are present in water. For example, at 293°C (68°F), the OC

Table 1. Notations.

Notation	Description
EIC	Electret ion chamber
LS	Liquid scintillation method
U.S. EPA	United States Environmental Protection Agency
PA-DER	Pennsylvania Department of Environmental Resources
REI	Rad Elec Inc.
PSU	Pennsylvania State University
LLRML	Low Level Radiation Measurements Laboratory of PSU
D	Delay time in days reckoned from the time of collection to the time of starting measurements
T	The period of E-PERM measurement in days, also called analysis time
λ	Decay constant of ^{222}Rn (d^{-1})
VA	Volume of air in the analysis jar
VW	Volume of the water in the analysis jar
OC	Ostwald coefficient
ARC	Average radon concentration in the analysis jar measured over the analysis period of T days
IRC	Initial ^{222}Rn concentration in the analysis jar at the time of the start of the measurement
RWC	Dissolved ^{222}Rn water concentration water when introducing it into the chamber
CRWC	Concentration of dissolved ^{222}Rn in water at the time of collection

for sea water is only about 0.17 while it is 0.26 for pure water.

Let us now calculate the expected ^{222}Rn concentration distribution between the air and water phase in an enclosed space when a known volume of water (VW) with a known ^{222}Rn water concentration (RWC) is placed into an enclosure. Let VA be the volume of air remaining in the large container after the addition of water. Much of the ^{222}Rn in water rapidly escapes to the air phase until equilibrium conditions are reached between air and water. Shaking or stirring the water phase more quickly brings the system to equilibrium. Let RA and RW be the equilibrium ^{222}Rn concentrations in water and air, respectively. By the definition of OC , we can write eqn (1) as follows:

$$OC = RW/RA. \quad (1)$$

A radioactivity balance before and after the addition of water leads to eqn (2):

$$(RWC)(VW) = (RA)(VA) + (RW)(VW). \quad (2)$$

[Note: In writing eqn (2), it is assumed that the amount of water that evaporates into the enclosed volume is small compared to the initial volume of water in the sample. Furthermore, it is assumed that all the ^{222}Rn in the analysis jar has come from ^{222}Rn in the water sample. The latter assumption may not be correct if the air originally present in the jar had some ^{222}Rn due to the presence of this gas in the room air. This interference can be minimized if the analysis is done in the laboratory where the ^{222}Rn concentration is small compared to that of the equilibrium ^{222}Rn concentration expected in the air phase inside the analysis bottle. However, it is best to set up this measurement in a room where the ^{222}Rn concentration in air is comparable with the ambient outside air. Outdoor or upper-level laboratories usually meet this requirement.]

Combining eqns (1) and (2) leads to eqn (3) or (4):

$$RWC = (RA)(VA/VW) + (RA)(OC), \quad (3)$$

or

$$RWC = (RA)[(VA/VW) + OC]. \quad (4)$$

When $VA \gg VW$, then the following is true:

$$RWC = (RA)(VA/VW). \quad (5)$$

Eqn (5) means that essentially all the ^{222}Rn has left the small water phase and is in its gas phase. Thus, by keeping the water volume small compared to the air volume, any error in the OC due to water hardness and temperature sensitivity is minimized.

Also, when $VW \gg VA$, then:

$$RWC = (OC)(RA). \quad (6)$$

This expression means that the OC is the controlling factor and should be accurately known when the

exposure volume is mostly filled with the water sample. Thus, this condition should be avoided.

The E-PERM measurement gives only the average ^{222}Rn concentration (ARC) over the period of measurement, whereas what is needed is the initial ^{222}Rn concentration (IRC) at the start of the measurement. We can now develop the relationship between these two quantities. Because the E-PERM is being exposed for approximately 1–3 d, there will be some decay in the ^{222}Rn concentration during the exposure time period. The voltage drop on the electret will be the result of the time integrated concentration (TIC) of ^{222}Rn during the exposure time period. From radioactivity decay considerations, the following equation can be written, which puts TIC in terms of IRC:

$$TIC = (IRC) \int_0^T \exp(-\lambda t) dt, \quad (7)$$

where λ is the decay constant of ^{222}Rn (0.1813 d^{-1}) and T is the exposure time period in days.

Integrating eqn (7) leads to eqn (8):

$$TIC = \frac{(IRC)[1 - \exp(-\lambda T)]}{(\lambda)}. \quad (8)$$

The ARC, as measured by E-PERM, is given by eqn (9):

$$\begin{aligned} ARC &= \frac{(TIC)}{(T)} \\ ARC &= \frac{(IRC)[1 - \exp(-\lambda T)]}{(\lambda T)}. \end{aligned} \quad (9)$$

Putting eqn (9) in terms of the IRC leads to eqn (10).

$$IRC = \frac{(ARC)(\lambda T)}{1 - \exp(-\lambda T)}. \quad (10)$$

Noting that IRC is the ^{222}Rn concentration at the time of the start of the E-PERM measurement time period, it is possible to substitute eqn (10) into eqn (4). This leads to eqn (11):

$$(RWC) = \frac{(ARC)(\lambda T)[(VA/VW) + OC]}{[1 - \exp(-\lambda T)]}. \quad (11)$$

If the sample was collected D days before the start of the E-PERM exposure time period, then the decay-corrected collection radon water concentration (CRWC) is given by eqn (12):

$$(CRWC) = \frac{(ARC)(\lambda T)[(VA/VW) + OC]}{[\exp(-\lambda D)][1 - \exp(-\lambda T)]}. \quad (12)$$

The right-hand side of eqn (12) contains known quantities, except for the ARC which is measured by the E-PERM following standard procedure. Therefore, it is possible to calculate the radon-in-water concentration at the time of collection. Please see Table 2 for a summary of the notations used in these equations. Note

Table 2. Ostwald coefficients at equilibrium saturation pressure for radon and water at different temperatures.

Temperature		Ostwald coefficient
°C	°F	
273	32.0	0.5249
278	41.0	0.4286
283	50.0	0.3565
288	59.0	0.3016
293	68.0	0.2593
298	77.0	0.2263
303	86.0	0.2003
308	95.0	0.1797
313	104.0	0.1632

that consistent units must be used. If ARC is given in Bq L^{-1} , then CRWC will be given in Bq L^{-1} . If λ is given in d^{-1} , then T and D must be given in days. VA and VW also must have the same units.

In the standardized system used for the experiments, the following were the values for the constants in eqn (12): $VW = 0.067 \text{ L}$; $VA = 3.76 \text{ L}$; $\lambda = 0.1813 \text{ d}^{-1}$; $OC = 0.26$.

RESULTS

The object of the experiments was to determine the concentration of dissolved ^{222}Rn in water samples by both the EIC method and the standard liquid scintillation (LS) method, and then compare the results at different concentration levels. The same samples collected at the same time from the same source were allowed to decay to different concentrations by allowing them to have different decay times (D) before performing their analysis.

Samples were analyzed in sets of five. The first set of five samples was analyzed by the EIC method and the next set was analyzed by the LS method. The LS analysis was done at Pennsylvania State's Low Level Radiation Monitoring Laboratory (LLRML) using an LKB Model 1219 liquid scintillation counter.

The LLRML is a U.S. EPA and PA-DER (please see Table 1 for notations) certified laboratory for the analysis of radioactivity in drinking water. The results of these analyses are given in Table 3.

Table 3 also gives the delay time (D) and sample analysis time (T). Results listed under EIC and LS are the results obtained by using the EIC and LS methods, respectively, after correcting for the delay time (D). ^{222}Rn in water at the time of measurement is simply the ^{222}Rn concentration assuming the delay time is 0 d. Table 3 lists the ratio of LS results to EIC results for each set of measurements. Wherever LS data is not available (e.g., for the fourth and fifth sets), the average of LS results is used for computing the ^{222}Rn in water concentration at the time of measurement and also for calculating the ratio of average LS to the average EIC

Table 3. Results of relative evaluation of the EIC and LS methods.

Serial number	Delay time (d)	Sampling time (d)	Radon (EIC) in water (pCi L ⁻¹) (Bq L ⁻¹)		Radon (LS) in water (pCi L ⁻¹) (Bq L ⁻¹)		Ratio of LS to EIC
1	0.958	1.04	75,100	2,778	83,500	3,090	1.15
2			71,800	2,656	82,600	3,056	
3			68,200	2,523	85,500	3,164	
4			75,400	2,790	83,800	3,101	
5			75,300	2,786	85,400	3,160	
Average: (% SD)			73,160 (±4.3%)	2,706	84,200 (±1.5%)	3,115	
²²² Rn in water at time of measurement: 71,800 pCi L ⁻¹ or 2,657 Bq L ⁻¹							
1	7.958	1.04	74,800	2,768	88,100	3,260	1.21
2			73,500	2,720	91,902	3,400	
3			76,600	2,834	90,500	3,349	
4			72,500	2,683	88,200	3,263	
5			73,100	2,705	89,700	3,319	
Average: (% SD)			74,100 (±2.2%)	2,741	89,700 (±1.8%)	3,319	
²²² Rn in water at time of measurement: 19,900 pCi L ⁻¹ or 736 Bq L ⁻¹							
1	14.98	1.04	81,000	2,997	83,800	3,100	1.07
2			81,600	3,019	83,000	3,071	
3			81,800	3,027	86,000	3,182	
4			87,100	3,223	88,700	3,282	
5			71,300	2,638	87,600	3,241	
Average: (% SD)			80,560 (±7.1%)	2,981	85,800 (±1.8%)	3,175	
²²² Rn in water at time of measurement: 5,675 pCi L ⁻¹ or 210 Bq L ⁻¹							
1	22.13	3.02	83,300	3,082			1.10
2			79,400	2,938			
3			78,200	2,893			
4			82,900	3,067			
5			69,700	2,580			
Average: (% SD)			78,700 (±7.0%)	2,912			
²²² Rn in water at time of measurement: 1,567 pCi L ⁻¹ or 58.0 Bq L ⁻¹							
1	33.0	3.73	74,100	2,741			1.09
2			88,900	3,289			
3			83,000	3,182			
4			68,100	2,520			
5			83,000	3,071			
Average: (% SD)			79,420 (±10.3%)	2,912			
²²² Rn in water at time of measurement: 220 pCi L ⁻¹ or 8.08 Bq L ⁻¹							
Grand average of ratio of LS to EIC: 1.124 ± 0.056							

at the corresponding concentrations. Note that measured results are rounded to three significant digits and the calculated results are not rounded.

Table 4 gives similar results and is taken from a published document (Heim and Granlund 1991). This was a blind test conducted by the PA-DER in an effort to evaluate different technologies and different laboratories performing ²²²Rn-in-water analysis. Samples were sent to laboratories for analysis. The table lists the intercomparison of results of measurements conducted by the U.S. EPA laboratory at Montgomery, AL, using the LS method and the EIC measurements conducted by Rad Elec Inc. laboratories on the samples collected

from the same source. Note that the results are not rounded to significant digits because this was the way that results were published in the original publication.

DISCUSSION

The following observations are made from the table of results:

1) The standard deviation (SD) of the set of five EIC measurements ranged from 4 to 11%. Even at low concentrations, below the U.S. EPA recommended limit of 300 pCi L⁻¹ (11.1 Bq L⁻¹), the SD did not

Table 4. Results of blind tests conducted by PA-DER. LS results reported by the U.S. EPA are compared with EIC results reported by REI in the blind test.

Serial number	Delay time (d)	Sampling time (d)	Radon (EIC) in water		Radon (LS) in water		Ratio of LS to EIC
			(pCi L ⁻¹)	(Bq L ⁻¹)	(pCi L ⁻¹)	(Bq L ⁻¹)	
1	2.0	1.0	85,947	3,180	102,877	3,807	1.20
2			86,281	3,192	103,246	3,820	
3			86,000	3,182	103,047	3,814	
Average:			86,076	3,184	103,057	3,813	
(% SD)			(±2.1%)		(±1.8%)		
^{222}Rn in water at time of measurement: 71,713 pCi L ⁻¹ or 2,653 Bq L ⁻¹							
1	2.0	2.0	11,934	441	13,953	516	1.19
2			12,020	445	14,086	521	
3			11,771	436	14,285	529	
Average:			11,908	441	14,108	522	
(% SD)			(±1.1%)		(±1.2%)		
^{222}Rn in water at time of measurement: 9,817 pCi L ⁻¹ or 363 Bq L ⁻¹							
1	2.0	2.0	3,982	147	5,123	190	1.21
2			4,507	167	5,220	193	
3			4,298	159	5,105	189	
Average:			4,262	158	5,149	190	
(% SD)			(±6.2%)		(±1.2%)		
^{222}Rn in water at time of measurement: 3,583 pCi L ⁻¹ or 132 Bq L ⁻¹							
1	2.0	2.0	812	30.0	962	35.6	1.10
2			852	31.5	934	34.6	
3			882	32.6	910	33.7	
Average:			849	31.4	935	34.6	
(% SD)			(±4.1%)		(±2.8%)		
^{222}Rn in water at time of measurement: 650 pCi L ⁻¹ or 24.1 Bq L ⁻¹							
Grand average of ratio of LS to EIC = 1.18 ± 0.05							
Grand average of ratio of LS to EIC using all the results from Tables 3 and 4 = 1.147 ± 0.057							

exceed 11%. This is considered acceptable precision for making routine measurements.

2) The integrity of samples was good. There was no leakage of ^{222}Rn from the sample bottles, since the samples analyzed after different decay periods (1–33 d) led to the similar initial collection time ^{222}Rn concentration in water.

3) The results were again similar when the analysis time period was varied from 1–3 d.

4) Observations 2 and 3 lead to a conclusion that the theoretical developments done in the present work are satisfactory.

5) The results obtained by the EIC method are consistently lower than those obtained by the LS method. The ratio was about 1.14 ± 0.09 in the current work. The ratio was about 1.17 ± 0.08 for a similar comparison when the EPA did a LS analysis. There does not seem to be any systematic variation of this factor with the concentration of dissolved radon in water.

6) It is difficult to explain why the EIC results are consistently lower than the LS results. There could be some uncertainties in the theory developed in this work. For example, there could be some adsorption of radon in the analysis bottle or some loss of ^{222}Rn during the transfer process. It is, therefore, recommended that the results obtained by the EIC method, using the protocol

described in this work, should be corrected by multiplying the results by an average experimentally derived correction factor of 1.15 to bring the results into agreement with the LS method, if the LS method is considered correct.

Error analysis

The uncertainties in the volumes of the sample and analysis bottles were quite small based on the measurements done on a set of 10 units obtained from the same manufacturer. These uncertainties ranged from 1 to 2% and can be neglected. A major error was in the measurement of the ^{222}Rn concentration in air. A detailed error analysis procedure for the EIC method of measuring ^{222}Rn in air has been described elsewhere (Kotrappa et al. 1990). An example of the calculation of results and the error associated with these results is given in the Appendix. The errors in the measurement of ^{222}Rn in air was a controlling factor in the errors expected in the measurement of ^{222}Rn in water.

To further simplify the discussion, it can be assumed that 0.37 Bq L^{-1} (10 pCi L^{-1}) in air can be determined with better than 10% precision in a 1-d analysis. This translates to a ^{222}Rn of 22.2 Bq L^{-1} (600 pCi L^{-1}) in water when analysis is done immediately after collecting samples, using a 67-mL sample. If the

sample size is doubled to 134 mL, then 11.1 Bq L⁻¹ (300 pCi L⁻¹) in water can be measured with better than 10% precision.

If the measurement period is 3 d, the E-PERM method can make a ²²²Rn measurement of about 0.15 Bq L⁻¹ (4 pCi L⁻¹) with better than 10% precision. This translates to 107 Bq L⁻¹ (288 pCi L⁻¹) in water when analysis is done without delay after collecting samples, using a 67-mL sample. Further, if the sample size is doubled, it is possible to measure 5.3 Bq L⁻¹ (144 pCi L⁻¹) in water with the same precision.

There are two ways of improving the errors at lower concentrations. As previously shown, one way is to use a larger sample volume (134 mL). The theory holds good since the volume of water is still very small compared to air volume. Another way is to increase the analysis time from 1 d to several days.

The SD in the calibration correction factor derived in this work is about 6%. When this is added by quadrature to the precision error of 10% expected by the EIC method, overall error comes to about 12%.

Advantages and disadvantages of the procedure

The advantages of this procedure, compared to the LS method, are as follows:

- 1) Low cost: Any laboratory already equipped for ²²²Rn-in-air analysis using the EIC method can adopt the procedure with insignificant start-up costs.
- 2) Does not require special skills or training.
- 3) Sample volume and analysis times can be increased to minimize errors at low concentrations.

The disadvantage is that when the approximate concentration of ²²²Rn in water is unknown, it is difficult to choose the optimum analysis time and E-PERM type. A manual from the manufacturer offers guidance to overcome this limitation:

- 1) Collect at least three samples, using the third sample for a confirmation test, if necessary.
- 2) When sampling public water supply, use a 134-mL sample bottle and/or a 2-d analysis with a short-term electret in an S chamber (Kotrappa et al. 1990).
- 3) If the sample is from a private well, use a 67-mL sample bottle and a 1-d analysis using a long-term electret in an S chamber. If the electret voltage drop is <20 volts in 1 d, then immediately repeat the analysis with another sample with a short-term electret in an S chamber.
- 4) If the levels are expected to be very high (1,850 Bq L⁻¹ or ≥50,000 pCi L⁻¹), use a long-term electret with an L chamber.

Handle electrets with care, using the recommended quality assurance procedures.

CONCLUSIONS

The EIC method gives a low-cost alternative for measuring dissolved radon in water. The method does not require high skill and is within the reach of most radon-measuring companies. If used properly, the procedure can give measurements with an acceptable overall accuracy of about 12% over a wide range of concentrations down to 11 Bq L⁻¹ (300 pCi L⁻¹), the proposed EPA limit. This may be acceptable for routine field measurements of dissolved radon in water by large-number radon measurement companies that cannot afford the LS method.

Acknowledgements—The authors are grateful for the helpful discussions with J. C. Dempsey, L. R. Stieff, and T. Brubaker. We also extend our thanks to Lu Markland for editorial assistance.

REFERENCES

- Clever, H. L. Ed. Krypton, xenon and radon—gas solubilities. New York: Pergamon Press; Solubility data series 2, International Union of Pure and Applied Chemistry; 1979: 227–273.
- Countess, R. J. Measurement of Rn in water. *Health Physics* 34:390–391; 1978.
- Dixon, K. L.; Lee, R. G. Occurrence of Rn in well water. *J. Am. Water Works Assoc.* 80:65–70; 1988.
- Heim, D.; Granlund, C. Pennsylvania Department of Environmental Resources Rn in water measurement inter-comparison. Philadelphia, PA: The U. S. EPA International Symposium on Radon and Radon Reduction Technology; Paper III P-2; 1991.
- Kotrappa, P.; Dempsey, J. C.; Hickey, J. R.; Stieff, L. R. An electret-passive environmental Rn monitor based on ionization measurement. *Health Phys.* 54:47–56; 1988.
- Kotrappa, P.; Dempsey, J. C.; Stieff, L. R.; Ramsey, R. W. A practical electret-passive environmental Rn monitor. *Health Phys.* 58:461–467; 1990.
- Lowry, J. Measuring low Rn levels in drinking water. *J. Water Works Assoc.* 83:149–153; 1991.
- Mathieu, G. G.; Biscaye, R. A.; Lupton, R. A.; Hammond, D. E. System for measurement of Rn at low levels in natural waters. *Health Phys.* 55:989–992; 1988.
- Environmental Protection Agency. EPA 40 CFR, Parts 141 and 142; Fed. Register 56(1):33050–33127; 1991.
- U.S. Environmental Protection Agency. Two test procedures for Rn in drinking water. Inter-laboratory study. EPA/600/2–87/082; 1987.
- Vitz, E. Toward a standard method for determining waterborne radon. *Health Phys.* 60:817–829; 1991.



APPENDIX

Sample Calculation and Error Analysis

For further details, please refer to the paper (Kotrappa et al. 1990). This is only a simplified method of error analysis and is valid for measurement time periods >1 d and over electret voltage ranges from 200 to 750 volts.

Data

A long-term electret was used in an S chamber for analyzing Rn in the analysis bottle. Let the initial reading of the electret be 700 volts and the final reading be 650 volts. Let the analysis time (T) be 1 d and 3 h (1.125 d). Let the gamma radiation background at the place of testing be 0.010 uGy h^{-1} ($10 \text{ } \mu\text{R h}^{-1}$). Let the delay time (D) be 2 d.

$$ARC = \frac{(700 - 650)}{(C)(1.125)} - (0.085)(10), \quad (\text{A1})$$

where $C = 0.16 + 0.00006 (700 + 650)/2$ and ARC is

expressed as pCi L^{-1} . (Note: C is different if a short-term electret is used). $ARC = 221 \text{ pCi L}^{-1}$ or 8.18 Bq L^{-1} .

Error E is given by the following:

$$E = \sqrt{(ARC)^2 \left(0.0025 + \frac{2}{(700 - 650)^2} \right) + [(0.10)(10)(0.085)]^2}$$

$$= 12.7 \text{ pCi L}^{-1} \text{ or } 0.47 \text{ Bq L}^{-1}. \quad (\text{A2})$$

Percent error in ARC is $(100)(E)/(ARC) = 5.7\%$.

Errors in the VA and VW are negligible (1 to 2%).

Therefore, total error can be taken as the error in ARC 5.7%.

Using eqn (12) in the text, the collection time ^{222}Rn concentration in water comes out to be 722 Bq L^{-1} ($19,504 \text{ pCi L}^{-1}$) with about 6% error.